

CONTEC

MODUL 350

Instruction Manual
Betriebsanleitung
Instructions techniques

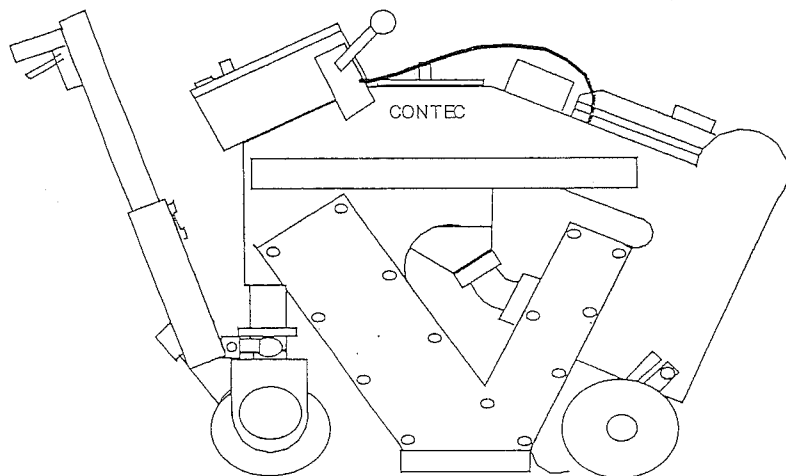

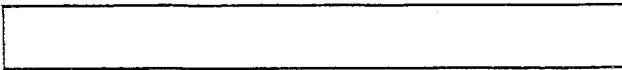

CONTEC

CE EG-Konformitätserklärung

Erzeugnis: Mobile Kugelstrahlmaschine
 Typ: MODUL 350
 Beschreibung: MODUL 350 400 V, 32 A, 50 Hz, 3 Phasen, 15.0 kW

Die Bauart des Geräts entspricht folgenden einschlägigen Bestimmungen: EG-Maschinenrichtlinie 89/392/EWG
 EG-Niederspannungsrichtlinie 73/23/EWG

Angewandete harmonisierte Normen: EN 292, Sicherheit von Maschinen, Geräten und Anlagen
 Angewandete nationale Normen und technische Spezifikationen: DIN EN 292

 Johannes Greb, Dipl. Ing

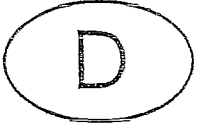

CONTEC

CE Déclaration de conformité CE

Produit: MODUL 350
 Type: MODUL 350
 Description: MODUL 350 400 V, 32 A, 50 Hz, 15.0 kW

La construction de l'appareil est conforme aux réglementations afférentes suivantes: Directive CE relative aux machines 89/392/EWG
 Directive CE relative à basse tension 73/23/EWG

Normes harmonisées appliquées: EN 292
 Normes nationales et spécifications techniques appliquées: DIN EN 292

 Johannes Greb, Dipl. Ing



CONTEC

CE EU Declaration of Conformity

Product: Mobile Shotblasting Machine
 Typ: MODUL 350
 Description: MODUL 350 400 V, 32 A, 50 Hz, 3 phase, 15.0 kW

The design of the unit corresponds to the following pertinent regulations: EC Machine Directive 89/392/EWG
 EC Low-Voltage Directive 73/23/EWG

Applied harmonised standards: EN 292
 Applied national standards: DIN EN 292

 Johannes Greb, Dipl. Ing



CONTEC

CE Dichiarazione di conformità CE

Prodotto: MODUL 350
 Tipo: MODUL 350
 Descrizione: MODUL 350 400 V, 32 A, 50 Hz, 15.0 kW

La costruzione de l'apparecchio è conforme alle seguenti direttive specifiche: Direttiva CE sulle macchine 89/392/EWG
 Direttiva CE sulla bassa tensione 73/23/EWG

Norme armonizzate applicate: EN 292
 Norme nazionali applicate e specifiche tecniche: DIN EN 292

 Johannes Greb, Dipl. Ing

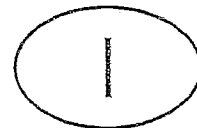

CONTEC

CE Atestato de Conformidad de la Unión Europea

Producto: MODUL 350
 Modelo: MODUL 350
 Descripción: MODUL 350 400 V, 32 A, 50 Hz, 15.0 kW

La construcción de la maquina corresponde a las siguientes normas específicas: Directiva de la UE para maquinas UE 89/392/EWG
 Directiva de la UE para baja tension 73/23/EWG

Normas armonizadas aplicadas: EN 292
 Normas nacionales aplicadas y especificaciones técnicas: DIN EN 292

 Johannes Greb, Dipl. Ing

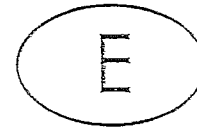

CONTEC

CE EG-Verklaring van overeenstemming

Produkt: MODUL 350
 Type: MODUL 350
 Beschrijving: MODUL 350 400 V, 32 A, 50 Hz, 15.0 kW

De constructie van het apparaat voldoet aan de volgende van toepassing zijnde voorschriften: EG-maschinenrichtlijn 89/392/EWG
 EG-laagspanningsrichtlijn 73/23/EWG

Toegepaste geharmoniseerde normen: EN 292
 Toegepaste nationale normen en technische specificaties: DIN EN 292

 Johannes Greb, Dipl. Ing



1.	<i>Introduction</i>	2
2.	<i>Concept</i>	3
3.	<i>Description</i>	5
3.1	External Control Panel Functio	6
3.2	Control Panel Contents	10
3.3	Shot Valve Lever and Shot Valve	12
3.4	Handle	13
3.5	Drive Unit	14
3.6	Blast Chamber and Blast Wheel	15
3.7	Magnetic frame	16
3.8	Reclaim Chamber	16
3.9	Separator and Shot Compartment	16
3.10	Blast Wheel Motor (Turbine Motor)	17
3.11	Belt Drive	17
3.12	Turbine Axis and Bearings	17
3.13	Rear Wheel Unit	18
4.	<i>Safety Rules for operating the MODUL 350 Shotblast Machine</i>	19
5.	<i>Operating and Blasting</i>	20
6.	<i>Maintenance & Adjustments</i>	22
6.1	Adjusting the Blast Track	22
6.2	Adjusting the Height of the MODUL 350	22
6.3	Wear & Tear on the Blast Wheel and Shot Cage.	22

6.4	Wear & Tear on the Linings	23
6.5	W&T on the Shot Stop in the Separator	24
6.6	Belt Drive	24
6.7	W&T on the Back Skirt	24
6.8	W&T on the Magnetic Frame and the Blast Opening	24
6.9	Bearings	25
7.	<i>Troubleshooting</i>	26
8.	<i>Technical data</i>	27
9.	<i>Appendix</i>	28
A:	Circuit Diagrams	28
B:	Order Numbers	30
C:	Wear & Tear parts	34
D:	Shot	34

1. Introduction

Thank you for deciding to buy the CONTEC MODUL 350 Mobile Shotblasting Machine.

MODUL 350 was developed for the blast removal and cleaning of horizontal surfaces such as Concrete, Asphalt, Steel and similar.

The heart of the machine is the so called Blast Wheel. Shot Medium (also known as Shot or Granules) is compelled via centrifugal force through the Blast Wheel at high speed onto the working / surface area. On impact, the shot medium rebounds from the surface area and is propelled through the Reclaim Chamber, through the Separator and then stored in the Shot Compartment. On impact particles from the working / surface area are removed and transported together with the shot medium back to the Separator. Here, the blasted material is separated from the shot. The Shot is then returned to the Shot Compartment, from where it continues to be propelled through the Blast Wheel completing the blasting cycle. The blasted floor particles are then sucked away to the waste compartment of the Dust Collector.

MODUL 350 operates on a dust free principle and can be used in large open areas or closed-in spaces. The internal separation and filtering of dust particles causes no pollution to the environment.

In the following pages, you will find all the necessary information, to achieve a safe, reliable and highly competent performance from the MODUL 350. It is therefore important to follow the strict guidelines for the deployment and servicing of the MODUL 350 in order to obtain optimum performance. It is in the interest of all persons operating or using the machine, to take note of the operating instructions in this manual in order to be fully conversant with the components and functions of the MODUL 350.

N.B. Please pay special Attention to the following information, when you see this sign.

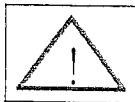

Following these straight forward guidelines will ensure efficient and reliable performance from the MODUL 350.

2. Concept

The majority of today's existing Mobile Shotblasting Machines are equipped with a single Blast Wheel. Other models are designed with two or more Blast Wheels. The principle of a system with two Blast Wheels is shown in Fig 1

This design is commonly produced with double or multiple housings which are made from a solid welded framework. The advantage of Mobile Shotblasters with more than one Blast Wheel is that the machine's height can remain small while the blasting width can increase.

Fig. 1

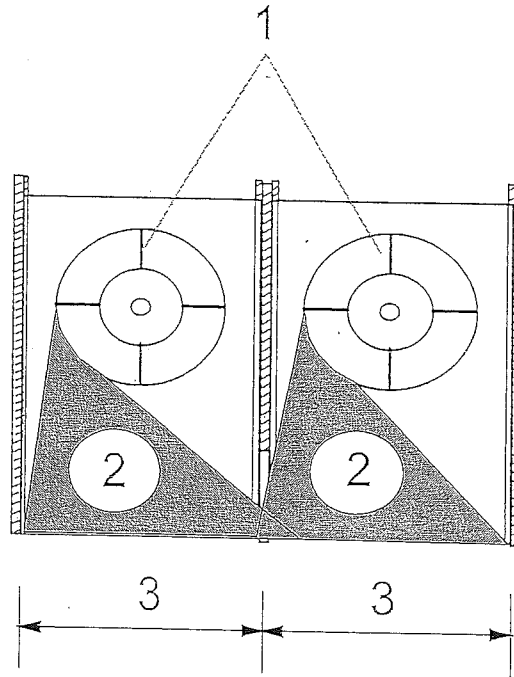

- 1 Blast Wheel
- 2 Blast Medium (Shot)
- 3 Blasting Width

A limitation in the deployment of Mobile Shot Blasting Machines is when the surface area to be blasted is too soft and the 'Rubber Ball' effect is deadened. The shot medium no longer rebounds independently back to the Shot Compartment store. This consequence is often referred to as 'carpet laying,' which means the shot loses its momentum and falls back down the Reclaim Chamber onto the work surface. At the same time the Blast Wheel continues to propel the shot from the Shot Compartment store thus emptying the machine of all its shot. This 'carpeting effect' is influenced by the hardness of the surface and the height of the Reclaim Chamber. It is generally accepted therefore that the higher the Reclaim Chamber, the greater the danger of 'carpeting' by the Shotblaster. In these circumstances, other surface preparation machines should be applied first, e.g. concrete planers and grinders.

Efficient working with Shotblasting machines in this competitive industry requires machines with increasingly larger working widths. Machines with a single Blast Wheel can achieve this only through an increase in size together with a higher positioning of the Blast Wheel. Consequently the height of the machine is significantly increased which results in much larger, overall dimensions. The resultant extended Reclaim Chamber then causing a longer return journey for the shot.

A lower positioned Reclaim Chamber is always a definite advantage in the versatility and function of the Shotblaster. Demonstrated in Fig. 2 is the modular concept of the CONTEC Mobile Shotblasting machine. Modular in this sense means that from the basic MODUL 350 Unit, more than one Extension Unit (MODUL 350 EU) can be joined onto the original unit.

The basic unit can be connected to a single Drive Motor and one main Control Panel. Subsequently all modular extension units correspond exactly with the original base unit and can be fitted accordingly. Therefore the working width can be effectively adjusted in line with the application required.

3. Description

In the following section the MODUL 350's essential parts and their functions are explained. Fig 3 depicts the schematic construction of a MODUL 350 basic unit.

1	Blast Chamber	10	Hose Connection	24	Rear wheel Unit
2	Reclaim chamber	11	Drive Wheel		
3	Separator	12	Back Wheel		
4	Shot Compartment	13	Belt Drive		
5	Turbine Motor	14	Magnetic Frame		
6	Control Panel	15	Shot Valve		
7	Drive Motor	16	Bearings		
8	Shot Valve Lever	17	Rubber Grip		
9	Dead Man's Switch	20	Side Cover		

Fig. 3

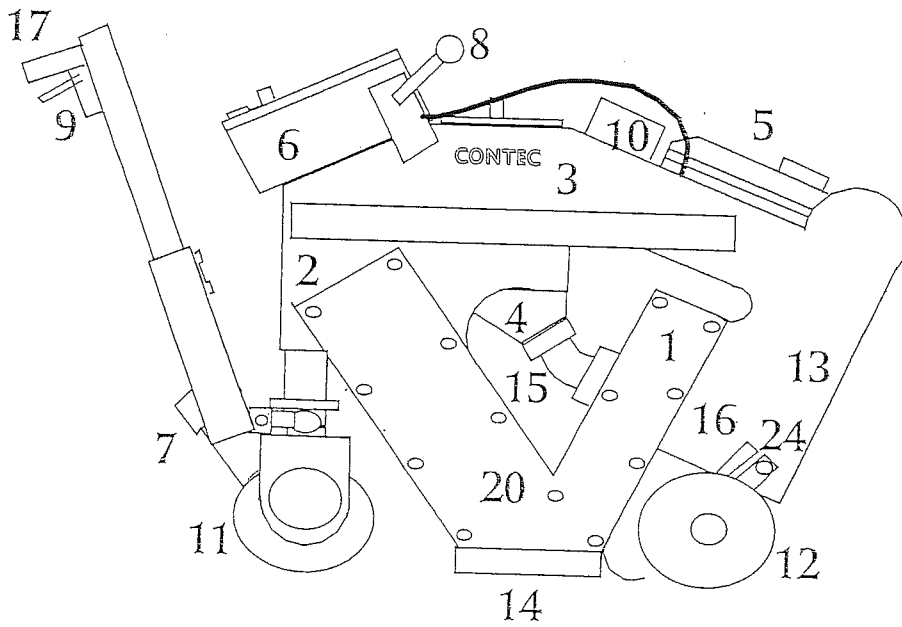

Parts of MODUL 350

3.1 External Control Panel Functions

Situated on the outside of the control panel are all the electrical controls and dials for the MODUL 350. According to the application required the control panel is suitable for the MODUL 350 base unit or for several extension units. It is also possible to change the panel for the addition of further unit(s)

Fig. 4 shows the Control Panel for the MODUL 350 + MODUL 350 EU.

1

Fig. 4

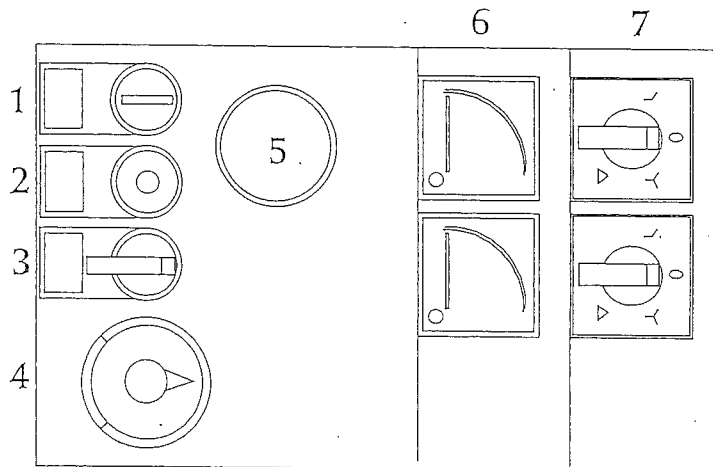

- 1 (START) Button
- 2 Operating (RUN) Indicator
- 3 Forwards / Reverse (I 0 II) switch
- 4 Speed Regulator
- 5 Emergency (STOP) Button
- 6 Ammeter for Power Consumption of Turbine Motor
- 7 Star Delta Switch for the Turbine Motor

➤ (START) Button

The (START) Button activates the Shotblaster. This is only possible if the Emergency STOP Button is not depressed. If the machine is activated the operating (RUN) Indicator is lit. Only now is it possible to switch on the Drive Unit. After depressing the Emergency Switch the MODUL 350 has to be re activated by the (START) button. The same applies in the event of a power failure

➤ Operating (RUN) Indicator

The (RUN) Indicator signifies that the machine is now ready for operation. It indicates that both the Turbine and the Drive Motor can now be switched on.

➤ Forwards / Reverse (I 0 II) Switch

The Forwards / Reverse (I 0 II) Switch determines the direction of the machine - as depicted by the arrow in Fig. 5

Fig. 5

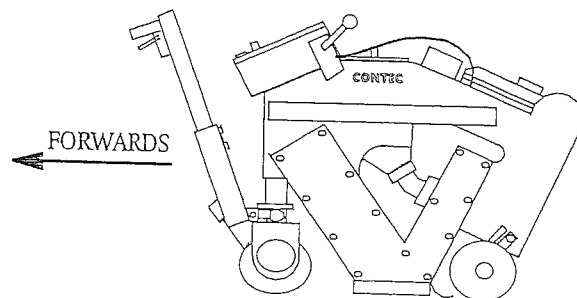

Reverse must only be used when the machine is not in operation i.e. to steer or position the machine



Before changing direction, the machine must be brought to a complete standstill. If not and the machine is switched on while still moving, the drive motor may be destroyed.

➤ Speed Regulator

The Speed Regulator adjusts the speed of the machine. When positioned to the Left the machine stays still, to the Right position and the machine can reach it's maximum speed. The blast performance can be altered by changing the travel speed and by controlling the amount of shot allowed into the Blast Wheel. Slow speed and a completely opened Shot Valve allows a maximum shot blasting intensity. High speed and a partly opened Shot Valve allows a minimum blasting intensity.

➤ Emergency STOP button

The Emergency STOP button, when depressed, is a safety measure for the immediate cut out of the machine in the event of a dangerous situation or the machine going out of control. All electronic components are immobilised. The Turbine and the Drive Unit come to a standstill.



If the machine is stopped by the Emergency STOP button and the Shot Valve has not been closed, the Blast Chamber becomes filled with shot, blocking the Blast Wheel. If this is the case the Blast Chamber must be completely emptied before restarting the Turbine. (See Trouble Shooting)

➤ Ammeter

The Ammeter indicates the power consumption of the Turbine motor. The Three Phase 15 kW motor has a rating of 26 Amps. The power Ammeter dial reflects the power consumption of the Blast Wheel. If the wheel receives a large amount of shot - an intense blast performance, the power consumption of the Turbine increases. This is explained later in the manual.

➤ STAR DELTA Switch for the Turbine motor.

The STAR DELTA Switch activates the Turbine motor and Blast Wheel. The Turbine system comprises of the Blast Wheel motor, the Blast Wheel, Belt Drive, Driveshaft and Bearings. The switch activates the Turbine in progressive steps. If it is directly switched on the electric start up current would be too high causing the circuit fuses to blow. To prevent this, the motor is switched on in two stages.

By switching from O to Star (Y) position the engine turns over with a low power consumption. When the required RPM is reached it then safe to switch to the Delta (A) position whereby the motor runs at full performance. In order to change the rotation of the Blast Wheel, first switch the Shotblaster off, disconnect the main cable and simply turn two of the pins in the plug with a screwdriver. The correct rotation is shown in Fig 6.

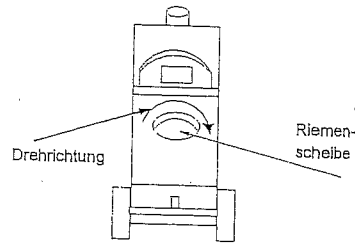
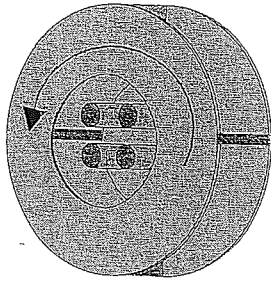

Fig. 6

The Blast Wheel must rotate in an anticlockwise direction. The Blast Wheel is not visible in the machine. This picture serves only to depict the direction of rotation.

On the rear side of the machine you can see the pulley through an opening in the Belt Drive Safety Cover. The pulley must rotate in a clockwise direction.



The CONTEC MODUL 350 Shotblaster only works in the correct rotation. Continuous operation in the wrong direction may destroy the Blast Wheel.

➤ Circuit for the Drive Unit

In the Control Panel is the circuit for the Drive Unit of the MODUL 350. Working together with the Speed Regulator on the top of the panel, controls the Drive Unit motor and the speed of the Shotblaster. No changes what so ever should be made to this fundamental circuit.

Positioned on the circuit are two miniature fuses. In the event of the Drive Unit stopping immediately, it is possible that one of the fuses has burnt out. This can happen as a result of high current peaks in the power supply or by sudden strain on the drive unit. In this case check the fuses and change them if necessary.

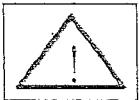

Only use fuses of the same rating capacity as installed on the circuit. The fuses are interchangeable in the fuse holders. Changing of these fuses does not affect the CONTEC warranty as they are not sealed.

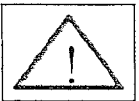

There are a number of Potentiometers on the circuit. Only professionals are allowed to adjust them. Further technical documentation can be found in the appendix of this manual.

Also in the Control Panel Cabinet are the Cable Trunks, Motor Overload Protection, Circuit Breaker, the Main Contactor, the Hour Counter and the Mounting Rail.

➤ Motor Overload Protection

The Motor Overload Trip protects the Turbine motors from overload over a long period of time.

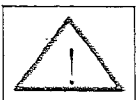

It is possible to open the Shot Valve so far that the Turbine motor is consuming more than the rated current (26 amps, 15 kW) over a longer period. In this case, the Motor Overload Trip switches off. It is not possible and therefore not recommended to switch it back on immediately.

3.2 Control Panel Contents

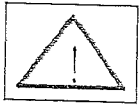

The Control Panel may only be opened when the power supply is disconnected !

Inside the Control Panel is the main Contactor. The Motor Overload Protection and the fuses for the Drive Unit and Control Circuit. Fig. 7 depicts an opened Control Panel. It must be emphasised that only qualified trained professionals are allowed to open and examine the Control Panel.

Fig. 7

- 1 Circuit for the Drive Unit
- 2 Star Delta Switch
- 3 Ammeter
- 4 Emergency Stop Button
- 5 Start Button
- 6 Machine running indicator
- 7 Forward / Reverse Switch
- 8 Speed Regulator
- 9 Mounting Rail
- 10/11 Cable Trunk
- 12 Motor Overload Protection
- 13 Control Circuit Fuse
- 14 Drive Unit Fuse
- 15 Main Contactor
- 16 Hour Counter
- 17 Transformer

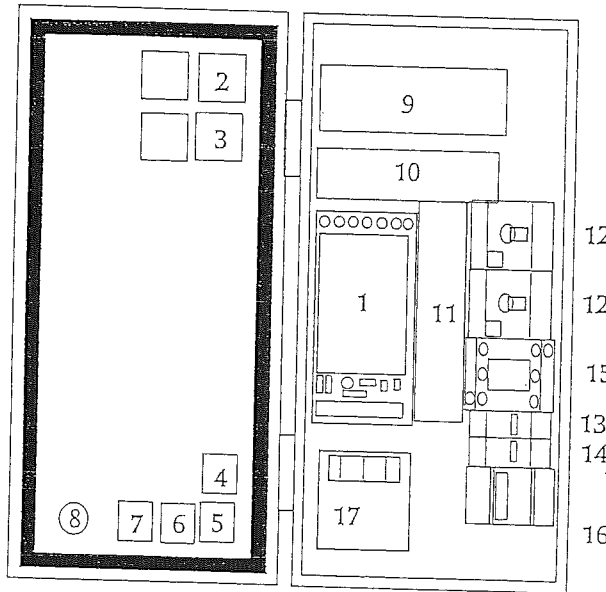

After a cooling down period it is possible to switch on again using the black button. The CONTEC Shotblaster can now be mobilised again. As discussed in the Emergency Button paragraph, it is possible that the Blast Chamber will be filled with shot because the valve was not closed. The Turbine is blocked and you must empty the chamber before restarting the machine.

➤ Control Circuit Fuse

The Control Circuit Fuse protects the machine against a short circuit in the main Contactor or any one of the other switches.

➤ Drive Unit Fuse

The Drive Unit Fuse protects against a short circuit or overload in the drive unit. (Motor cable, circuit and switches).

➤ Main Contactor

The Main Contactor activates the electrical system of the machine by the pressing of the START button.

➤ Hour Counter

The Hour Counter indicates the time which MODUL 350 was active in hours by the illumination of the white light.

3.3 Shot Valve Lever and Shot Valve

To the right of the Control Panel, is a lever with which you can open, close and adjust the Shot Valve, thereby regulating the amount of shot entering the Blast Wheel. When the lever is pointing away from the operator, the valve is closed. The more the operator pulls the lever towards himself, the more the Shot Valve opens. This causes more shot to reach the Blast Wheel increasing the blast performance. The performance is reflected, in the power consumption of the Turbine motor, as explained in the "Ammeter" section.

Before opening the valve, please pay attention to the following four points:

- The Turbine **MUST** be switched on. If the Blast Wheel is not rotating, the Blast Chamber will be filled with shot and the Turbine then blocked. In this case, attempts to switch on the Turbine, could damage the Belt Drive and motor.

- ☑ The Blast Wheel MUST spin in the correct direction as explained in the section "Star Delta Switch" above.
- ☑ The machine MUST now be moving. If the Shot Valve is opened while the machine is not moving, deep holes will be blasted into the floor. The same applies if the machine is stopped before closing the Shot Valve.
- ☑ The more the Shot Valve is opened, the greater the blast performance achieved. The greater the blast performance, the greater the power consumption of the Turbine motor. Depending on the quantity of shot used, it is possible to overload the motor. If the Turbine motor is operated for some time over the stated current, the Motor Overload Protection Trip automatically switches the machine off. (See Motor protective above). While blasting, pay attention to the ammeter and make sure, that the consumption is not more than 26 Amps.

3.4 Operating Handle

The Handle, situated at the front of the MODUL 350 steers, lifts and activates the Drive Unit. By depressing the Drive Unit Lever, the Shotblaster will start to move. The machine is steered by moving the handle to the left or right. By pressing the handle down, the machine can be lifted. If the Magnetic Frame of the machine is touching the floor it may slow down or even stop. By gently lifting the machine it will start to move again. If the lever is released, the Drive Unit switches off and the Shotblaster will stop immediately.



Close the Shot Valve before switching off the Drive Unit !

The Drive Unit Lever is a safety measure, which prevents the MODUL 350 from moving without an operator.

3.5 Drive Unit

The construction of the Drive Unit is shown in Fig. 8. It consists of the Drive Motor, Gear Box, Inner and Outer axle, Clutch Pin, Bearings and Drive Wheel. The Drive Wheel is connected to the Drive Motor by pushing the Clutch Pin through the hole in the Outer axle and into the hole of the Inner axle. Should there be a problem in pushing the pin through these holes, follow this procedure:

- a) Activate the MODUL 350 by pressing the START button.
- b) Move the Speed Regulator to the Left-hand side for a slow speed.
- c) Press the Drive Unit Lever with the left hand and press the Clutch Pin with the right hand in the hole of the Inner axle. The Inner axle will start to move and as soon as both holes are lined up, the Pin can be pushed inside.

Fig. 8

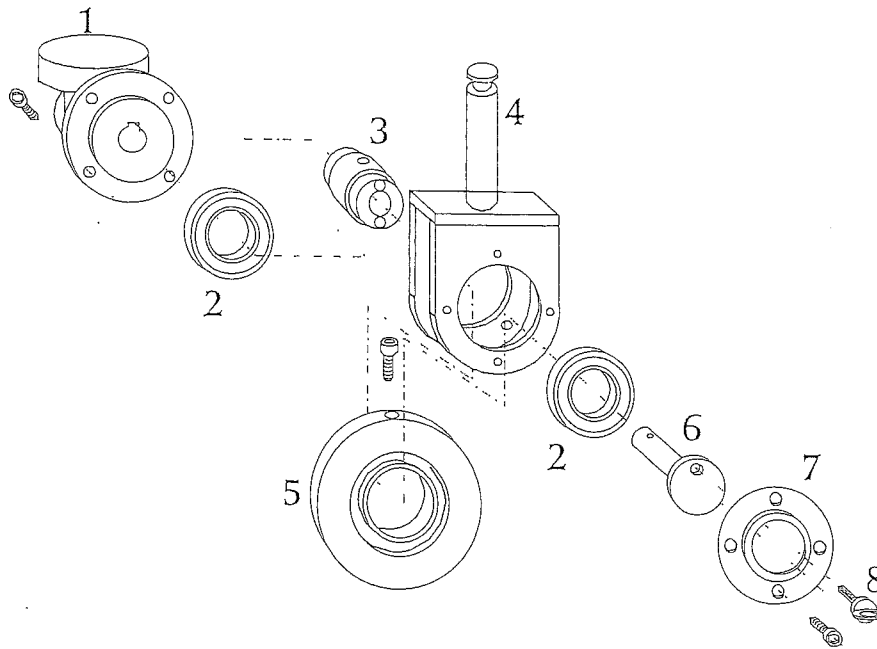

- 1 Drive Motor and Gear Box
- 2 Bearings
- 3 Outer Axle
- 4 Drive Unit Housing
- 5 Drive Wheel
- 6 Inner Axle
- 7 Clutch Cover
- 8 Clutch Pin

3.6 Blast Chamber and Blast Wheel

Situated in the Blast Chamber is the heart of the machine, the Blast Wheel. The shot passes through the Shot Valve, the flexible, plastic Shot Hose, enters the Shot Pipe and the Shot Cage to the Blast Wheel. Fig. 9 shows the construction of these parts.

The Fingers in the centre of the wheel throw the shot through the window of the fixed cage. The shot then makes contact with the blades at a certain point. With the assistance of the centrifugal force, the blades accelerate the shot and it impacts the floor with high energy. When successful, the whole underside opening of the Shotblaster is covered with Shot. At the point where the shot leaves the wheel, it scatters, fan-like in the direction of the floor. The direction, in which the "blast fan" leaves the Blast Wheel depends on the position of the window in the shot cage. Turning the position of the Shot Cage window, allows the smoothness of the blast surface to be adjusted. (See the Maintenance & Adjustments Chapter)

Fig. 9

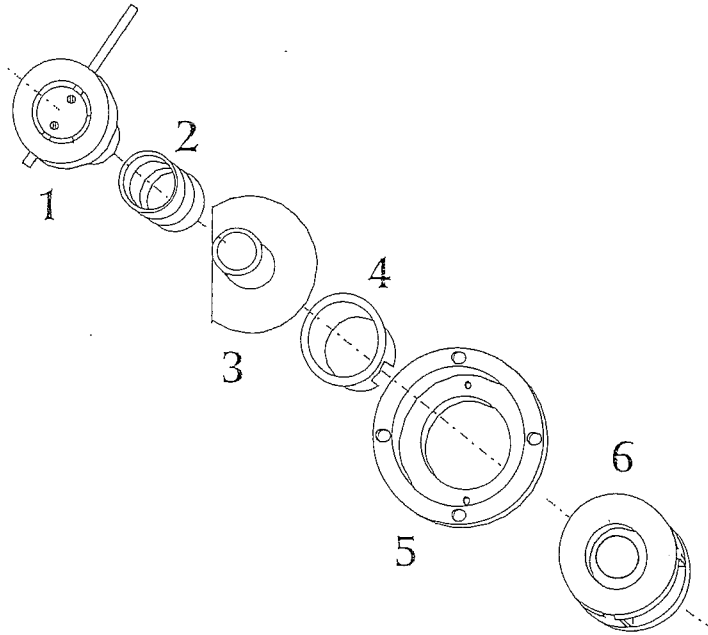

- | | | | |
|---|-------------------|---|-------------|
| 1 | Shot Valve | 6 | Blast Wheel |
| 2 | Shot Hose | | |
| 3 | Shot Enter Pipe | | |
| 4 | Shot Cage | | |
| 5 | Blast Wheel Cover | | |

3.7 Magnetic frame

On both of the outside edges and on the front of the Blast Opening are magnetic seals. These seals are complemented by rubber strips on each side. Stray shot stays between the Magnetic Frame and the floor creating a buffer. This means, that the airflow is mostly forced to the rear of the Blast Opening. Lost shot is sucked back to the opening and rejoins the blasting cycle.

The Skirt on the rear of the Blast Opening also serves as a seal on the MODUL 350. The sealing effect is not achieved by magnets, but through the Skirt lying snug to the floor.



The Skirt can be damaged by reversing the machine. Take extra care with uneven floors !

3.8 Reclaim Chamber

The Reclaim Chamber serve guides the shot back through the Separator into the Shot Compartment. When striking the floor, the shot rebounds like a rubber ball at the same angle as it had on impact. This force alone is enough to carry the shot back to it's compartment. The air flow from the Dust Collector serves only to separate the dust from the shot, maintaining a totally dust free operation.

3.9 Separator and Shot Compartment

The Separator is situated above the Shot Compartment and separates the incoming mixture of shot and dust from the Reclaim Chamber. Due to the difference in the density of the dust compared to the shot, the lighter dust is taken away by the air flow into the Dust Collector. The heavier shot falls back into the Shot Compartment.

Often during the course of blasting, foreign bodies such as screws and stones can be carried to the separator. A sieve between the Separator and the Shot Compartment prevents these from entering the Blast Wheel.



Blasting without the sieve can destroy the Blast Wheel !

To clean the sieve remove the lid of the Shot Compartment. It is now possible to take the sieve out of the machine. On the under side of the lid is a Shot Stop. This absorbs the energy of the shot which arrives at high speed. It protects the machine and is a Wear & Tear part. Be sure to check it on a regular basis.

On the lower side of the Shot Compartment is the Shot Valve. By opening the valve, the shot is introduced to the Blast Wheel for the machine to begin blasting. The valve is adjusted by a lever and a remote control which is described above (3.3). The length of the remote control cable changes with continued use. The consequence is a change in the position of the valve. If the valve is not closing properly, adjust its position with the two nuts on the end of the cable.

3.10 Blast Wheel Motor (Turbine Motor)

The Blast Wheel Motor delivers the power needed for blasting floors. The standard version of the MODUL 350 is equipped by a 3 phase, 15 kW motor.

3.11 Belt Drive

The Belt Drive transfers the power from the Blast Wheel motor to the Blast Wheel axle and thereby the Blast Wheel. MODUL 350 uses a silent and serviceable Poly-V belt drive.



Never switch on the Turbine without the Belt Drive Safety Cover in position!

The tension of the Belt has to be checked on a regular basis. If the Belt is too loose it will slip on the pulley. This decreases the life of the Belt and the blast performance. For adjusting the tension of the Belt, please see the 'Maintenance and Adjustments' Chapter.

3.12 Turbine Axle and Bearings

The Turbine axle is in two standard bearing housings. The housings are filled with grease and don't need to be maintained during their lifetime. In the event of a greasy film appearing on the housings, tighten the screws which connect the two halves.

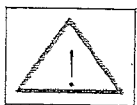

The two halves of the housings are not changeable. They are marked with dots. One housing has one dot per half, the other one has two.

3.13 Rear Wheel Unit

The Rear Wheel Unit of the MODUL 350 works like a seesaw. It has two functions. First it adjusts the height of the machine. Secondly, the whole machine can be lifted approximately 8 cm for easier transportation. In between the rear wheels on the axle is a pin. By slotting the lifting bar over this pin the machine can be lifted as shown in Fig. 10.

Fig. 10

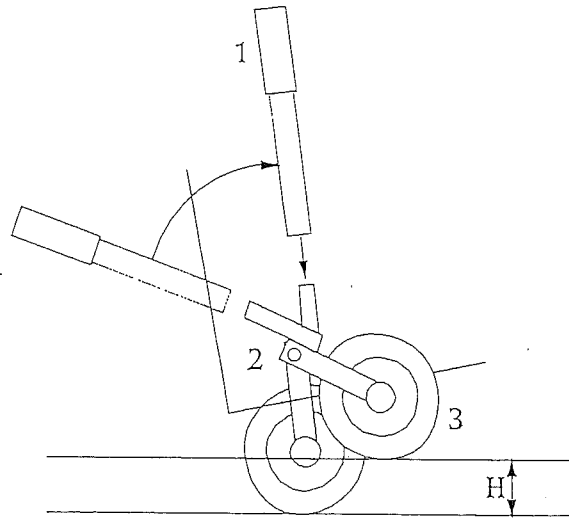

- 1 Lifting Bar
- 2 Rear Wheel Unit (Seesaw)
- 3 Rear Wheel

If the machine is lifted, make sure that it can't slip down from its raised position. Place the Clutch Pin in the hole of the side plate.

4. Safety Rules for operating the MODUL 350 Shotblast Machine

The MODUL 350 Mobile Shotblast Machine is constructed according to existing safety rules and regulations. These technical precautions should not be removed or changed under any circumstances. While operating the machine the following items should also be kept in mind:

- Disconnect the machine before commencing any servicing or maintenance work - however menial. Never unplug the machine while it is still running.



This notice can be found in every manual but in nearly every part of the MODUL 350 high electrical currents are transmitted. The danger of injury is therefore not only from electric shock, but also from moving parts of the machine.

- It is necessary to use safety goggles with side protectors and ear plugs. All persons, in the operating area of the Shotblaster must take these precautions. When switching on, or lifting the machine during blasting, it is possible that shot escapes at high speed. Unprotected eyes can be seriously damaged in this case.
- Never wear loose or badly fitting clothing. Flapping sleeves may be pulled into the machine causing serious injury.
- All rotating parts of the machine are suitably protected by covers, which prevent clothes or similar from entering the machine. Under no circumstances should these covers be removed before you switch the machine on.
- Access by unauthorised persons into the blasting area should be prevented. (Due to a high risk of slipping on lost shot)
- The MODUL 350 should be switched off immediately if unusual noises or vibrations are detected during the operating of the machinery. A thorough check must be carried out in order to detect the cause.
- Always pre check the floor for undulation, stones, screws or other foreign bodies. It might be necessary to brush, or in extreme cases, vacuum the floor. Wet or oily spots can make blasting impossible and damage the Dust Collector.
- Check the power cables regularly as damage may have occurred while operating the machine. Always disconnect the cables before examination and treat all electrical parts with extreme care.

5. Operating and Blasting

Operating the MODUL 350 has to be carried out according to the safety rules in Chapter 4.

Transport the MODUL 350 and the Dust Collector to the floor which is to be blasted. Lifting the machine, as discussed in Chapter 3 (Rear Wheel Unit) will make transportation somewhat easier.

Check and make sure that all Wear & Tear parts (defined in the appendix) are in good condition. If there are any doubts, replace them immediately. Check the power cables.

Connect MODUL 350 with the hose to the Dust Collector. It is important, that there are no lesions or holes in the length of hose. Even small holes or a bad connection can significantly decrease the performance of the dust collector.

Connect the power cables of MODUL 350 and the Dust Collector to the sockets. Insulation tape or similar can be used to secure the power cable to the hose. The basic unit MODUL 350 only needs a 32 A, 3 phases+Earth connection. When operating a Double Unit (MODUL 350 + MODUL 350 EU) a 64 A, 3 phases+Earth connection is required.

Check the floor for screws, nuts or stones etc., and sweep the floor if necessary with a brush or a vacuum system. Small obstacles like joints pose no problems for MODUL 350. If there are bigger undulations or similar check if it is possible for the machine to drive over them before the Turbine is switched on.

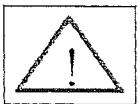

In the case of severe undulations or difficult joints on the floor it is possible for the Magnetic Frame of the machine to rise too far above the floor. The sealing of the Shotblaster becomes ineffective and shot escapes from the machine at high speed. This can cause injury to persons and equipment. Before operating always check the condition of the floor to prevent this from occurring.

Remove the Shot Compartment Lid. Make sure that the Shot Valve is closed and fill the Shot Compartment with shot until level with the sieve. Do not fill above the sieve level as suction from the Dust Collector will suck it away with the dust.



Only place new or clean shot in the Shot Compartment.

Clean the sieve in the Shot Compartment if it is blocked.

Take the Clutch Pin out of the drill in the side plate of the machine and put it into the holes of the Drive Axle. (Chapter 3, Drive Unit). Take the lifting bar and put the machine in the lower position. (Chapter 3, Rear Wheel Unit)

Check the distance of the Magnetic Frame to the floor. The basic rule is the closer to the floor the better. Unfortunately floors are never ideal and mostly uneven. The distance has to be adapted to the floor but should never be more than 10 mm.

Switch the Dust Collector on.

Pull out the Emergency STOP button and press the START button.

Press the lever of the Drive Unit switch and check the direction and the speed. With the direction Forward / Reverse switch it is possible to change the direction. Only blast in the direction marked 'Forward' in Fig. 5. The speed is regulated by the Speed Regulator on the lower right end of the Control Panel. Drive the machine to the place where blasting should begin.

Now turn the Star Delta switch of the Turbine motor. Make sure, that the blast wheel is rotating in the correct direction. (Chapter 3, Star Delta switch). In the case of wrong rotation, switch the Shotblaster off and turn the two pins in the plug of the machine cable.

Press the lever of the Drive Unit switch. MODUL 350 will start to move with a time delay. Open the Shot Valve slowly with the Shot Valve Lever. Do not attempt to open it before the machine is moving or deep holes will be blasted into the floor.

The Ammeter on the control panel indicates the power consumption of the Turbine motor. Make sure that the consumption is not higher than 26 A. (standard version with 15 kW 3 phase motor) The correct use of the Shot Valve is described in chapter 3.2 "Motor Overload Protection " and Chapter 3.3.

After a few meters of blasting close the Shot Valve and stop the machine. Check the track on the floor. If the track is not evenly blasted, adjust the position of the Shot Cage as described in the 'Maintenance & Adjustment' Chapter.

Repeat the blasting. When the machine is stopped it must be allowed to come to a complete standstill before switching on the Reverse Drive direction switch.

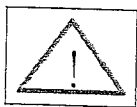

Abrupt reversing of the Drive Direction switch causes damage to the Drive Motor Drive Circuit. First stop the machine then reverse the switch !

The dust container of the Dust Collector has to be emptied on a regular basis. The intervals depend on the size of the container and on the condition of the floor.

6. Maintenance & Adjustments

6.1 Adjusting the Blasting Path

The blasting path is adjusted by turning the Shot Cage in the Blast Wheel Cover as shown in Fig. 9. If blasting leaves an uneven path, then one side of the path is being blasted more heavily than the other.

Remove the Shot Hose between the Shot Valve and the Shot Enter Pipe. The Shot Enter Pipe is secured with two clamps on the Blast Wheel Cover which can be removed by unscrewing two nuts. The Shot Cage is situated under and held in position by the Shot Enter Pipe.

If the Path is heavier on the left hand side compared to the right, turn the Shot Enter Pipe anti-clockwise. Turn in a clockwise direction if the path is heavier on the right hand side. Reconnect the Shot Enter pipe with the clamps, connect the Shot Hose and try a short test run. Repeat the adjustment if necessary until the path is smooth, even and without variation.

6.2 Adjusting the Height of the MODUL 350

There are three adjustable screws for changing the height of the MODUL 350. By changing the height, the gap between the floor and the Magnetic Frame is adjusted accordingly. For a more effective performance, the smaller the gap between floor and machine, the better. (Less Wear & Tear and loss of abrasive) However a rough, uneven floor requires a slightly larger gap than a smooth floor.

For changing the height of the front of the machine, the screws for adjusting are situated on the upper end of the Drive Unit Frame under the Control Panel. For the back of the machine, two screws are situated on the Rear Wheel Unit. Unscrew the nuts of the screws - this applies to all screws. Turning the screws clockwise lifts the machine, turning them anti clockwise lowers it. The gap between the Magnetic Frame and the floor should be the same all over. For most floors this figure is between 5 mm and 10 mm.

On the front and sides of the Magnetic Frame are rubber strips which act as protective seals against escaping abrasive. If the height of the machine is changed, the height of the rubber strips must also change accordingly. Slacken screws of the brackets which clamp the rubber strips and place them in the desired position. They should always lie snug to the floor.

6.3 Wear & Tear on the Blast Wheel and Shot Cage.

The Blast Wheel is a pure Wear & Tear part and must be checked regularly. CONTEC recommend a first check after 30 hours of blasting. The life of the Blast Wheel depends on the application of the machine.

For example a lot of Wear & Tear occurs when blasting soft concrete with a lot of surface fat. Concrete Dust is a very aggressive substance and increases Wear & Tear enormously. This decreases when blasting Steel or Ceramic Tiles. To give an accurate figure for the lifetime of the wheel is therefore impossible. As a rough guide, this could be anywhere between 30 and 100 hours.

Take off the Shot Hose in between the Shot Valve and the Shot Enter Pipe. Loosen the four nuts which secure the Blast Wheel Cover to the machine. Remove the Blast Wheel Cover carefully. Between the Blast Wheel Cover and the Blast Chamber is a rubber Sealing which may, during the process of operation stick to both sides. Pay special attention not to tear or rip it. Failure to do so will result in damage to this Sealing

Now the Blast Wheel should be visible. In the middle of the wheel there is a hexagonal shaped screw. Loosen the screw and remove the wheel from the Blast Chamber. Check the Wear & Tear on the Wheel. The thickness of the five blades should not be less than 4 mm. Also check the Distribution Fingers on the inside of the Wheel for Wear & Tear.

The Shot Cage is like the Blast Wheel - a pure Wear & Tear part and must be checked regularly. Two different kinds of Wear & Tear on the cage are possible. The window in the cage has a width of 45 mm. Change the cage if this width is more than 50 mm. The second type of Wear & Tear is the decrease in the thickness of the cage wall itself. Change the cage before a hole appears. If the Blast Wheel and Cage are in a good condition replace the parts using the opposite direction to that described above.

6.4 Wear & Tear on the Linings

The Blast Chamber and a large part of the Reclaim Chamber are protected by Linings. These prevent the machine from destroying itself. The Linings must be changed if the thickness is less than one third of the original thickness in any one place. The most Wear & Tear happens to the side and top linings of the Blast Chamber. The thickness of these linings is 10 mm. Should the Wear & Tear be more than 6 mm they must be changed. If they are changed too late, the machine will blast a hole in it's frame in a short time.

Changing of the Linings:

On both sides of the MODUL 350 are the Side Covers for the Shot Compartment, Reclaim Chamber and Blast Chamber. Remove the Side covers by loosening the screws. The Side Linings can now be easily removed. On the upper end of the Blast Chamber are three screws directly under the Turbine motor. Loosen the nuts of these screws and turn them out by 8 mm. The top lining can now be removed. If this proves difficult, tap gently, but firmly on both sides with a hammer. The motion of the hammer will remove trapped dust and shot which may hinder removal of the Linings.

The Front and Back Linings of the Blast and Reclaim Chambers are each secured by nuts on the outside of the chambers. Remove the Blast Wheel (Refer to 6.3 - Wear & Tear on the Blast Wheel and Shot Cage). Loosen the nuts and remove the linings. The installation of the new linings is the reverse procedure to removing them. The lifetime of the linings should normally be 200 hours. Again a precise figure cannot be given for the same reasons described for the Blast Wheel - i.e. depending on the application.

6.5 Wear & Tear on the Shot Stop in the Separator

On the inner side of the Shot Compartment Lid in the Separator is the Shot Stop. This takes away the energy of the high speed rebounding shot, thus preventing the destruction of the Shot Compartment. It also prevents the dust collector from sucking Shot out of the machine. The Shot Stop should be regularly checked. Changing the Shot Stop is easily done by removing the two screws on the Shot Compartment lid.

6.6 Belt Drive

The Belt Drive is made to last for at least 500 hours - but only if it tensioned correctly. To check the tension remove the Belt Drive Safety Cover. It shouldn't be possible to move the Belt Drive more than 1 or 2 cm in each direction half way between the pulleys. If it is too loose, adjust the tension by loosening the four screws which hold the Turbine motor. On the upper side of the Motor Flange is a nut. Turn this in a clockwise direction until the tension of the Belt is correct. Tighten the four screws of the motor and also tighten the nut.

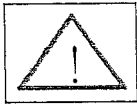

Secure the Safety Cover!

6.7 Wear & Tear on the Back Skirt

The Back Skirt on the rear of the Blast Opening serves to prevent shot from escaping and thereby minimises the loss of shot. If the Skirt is worn out it must be replaced. Remove the screws of the bracket which secures the Skirt. Remove the worn out parts, exchange them and replace the Skirt to it's former position

6.8 Wear & Tear on the Magnetic Frame and the Blast Opening

Around the Magnetic Frame are several parts which must be regularly checked. The parts are subjected to Wear & Tear through action of the Shot and through contact with the floor. In the front and side areas are the Magnetic Frames. These are easily removed. The Left and Right Frames are screwed to the Side Cover. The Front Frame is screwed to a bracket on the Reclaim Chamber. After removing the Magnetic Frame, on the rear side of the opening is another part. The Back Skirt is screwed to this part. Wear & Tear happens mainly to this part if it is in contact with the floor. As previously mentioned, it is important to check all parts regularly. In doing so, it is not necessary to unscrew the Magnetic Frame, just place the machine carefully on it's side and check for Wear & Tear.

6.9 Bearings

Bearings are always tricky in Mechanical Engineering. To change Bearings is generally simple if the rules are observed. However, for the purpose of this manual, too complex to describe in any detail. If you have any doubts always refer to trained or experienced engineer.

The bearings for the MODUL 350, are situated in the Motors, the Drive Unit Lever, the Turbine Axle Housings, the Drive Unit Frame and the Wheels. To change the Bearings in the Drive Unit Frame is no problem, (See Fig. 8). Remove the Drive Unit Motor on one side and the Drive Axle Cover on the other side. Now remove the Inner Axle. The Drive Unit Wheel is secured to the Outer Axle by two screws. Remove these and take out the Outer Axle. It is now possible to take out the wheel and the Bearings.

Never attempt to change the Motor Bearings by yourself. Return the motors to CONTEC or take them to a reputable Motor Rewind Technician. The Bearing housings are the most difficult items to deal with. The Bearings inside are under the greatest stress from the operating of the machine. The lifetime of such high speed revolving Bearings is between 500 and 1,000 hours. For skilled mechanics it is no problem to change the Bearings. (See also Blast Wheel Axle and Bearings - 3.12). In case of doubt send the machine or machine housing to CONTEC. You will find a list of the appropriate bearings in the Technical Data in Section 9 of this manual.

7. Troubleshooting

If, after activating the machine by pressing (START) the run lamp is lit but all or part of the motor is not running - Check the following:

- Is the power connection correct ? (400 V, 3 phases+Earth)
Are the cables in a good condition and properly laid ?
- Are the fuses in the Control Panel closed ?
Is the Motor Overload Protection closed ?

The Turbine Motor is not working.

- Has the Blast Chamber filled up with shot and blocked the Blast Wheel during transportation of the machine?
- Is the Motor Overload Protection in the Control Panel closed ?

The Drive Motor is not working.

- Is the fuse for the Drive Unit in the Control Panel closed ?
- Are both fuses on the Control Circuit OK ?
- Does the Drive Wheel turn easily when not connected to the Drive Motor ?

The blast performance is too low

- Is the Blast Wheel turning in the right direction.
Has the Blast Wheel worn out?
- Has the Shot Cage been correctly adjusted?
Is the Shot Cage worn out?
- Is the sieve in the Shot Compartment blocked ?
- Is the Shot Valve blocked ?
- Has the shot worn out (Check the size of the balls)

MODUL 350 works for a short time and then loses all the shot ('carpeting effect')

- Is the Blast Wheel rotating in the correct direction ?
Has the Blast Wheel worn out ?
- Has the Shot Cage been correctly adjusted?
Is the Shot Cage worn out?
- Do the Rubber Seals of the Magnetic Frame lie snugly with the floor ?
Are the Rubber Seals worn out?
- Is the height of the machine positioned too high?
- Is the Belt of the Turbine too loose ? (The Belt will slip on the pulleys and the Blast Wheel will not rotate quickly enough)
- Is it possible to blast the floor ? Check the condition. Is it dry and not too elastic or soft ?

8. Technical Data

MODUL 350

<i>Working breadth</i>	350 mm
<i>Drive unit</i>	DC motor with speed regulation
<i>Cleaning power</i>	100 to 300 m ² concrete per hour
<i>Turbine power</i>	15 kW (standard)
<i>Weight</i>	320 kg
Power Requirements	400 V, 50 Hz, 3 Phases, 26 A
Dimensions (length x height x width)	145 x 97 x 48 cm

MODUL 350 + MODUL 350 EU

Working breadth	715 mm
Drive unit	DC motor with speed regulation
Cleaning power	More than 300 m ² concrete per hour
Turbine power	2 x 15 kW (standard)
Weight	605 kg
Power requirements	400 V, 50 Hz, 3 Phases, 52 A
Dimensions (length x height x width)	145 x 97 x 89 cm

Bearings (Producer SKF)

Turbine Axle	2 x 22207 E
Bearing Housings (Seals are normally delivered with the housings)	2 x SNH 207 TA
Locating Rings	2 x FRB 5.5/72
Axle of the Drive Unit	2 x 61910-2RS1
Lift	2 x 6205 2Z

Electronics Control Panel	Klöckner Moeller
---------------------------	------------------

9. Appendix

A: Circuit Diagrams

© CONTEC MODUL 350
03.01.1998

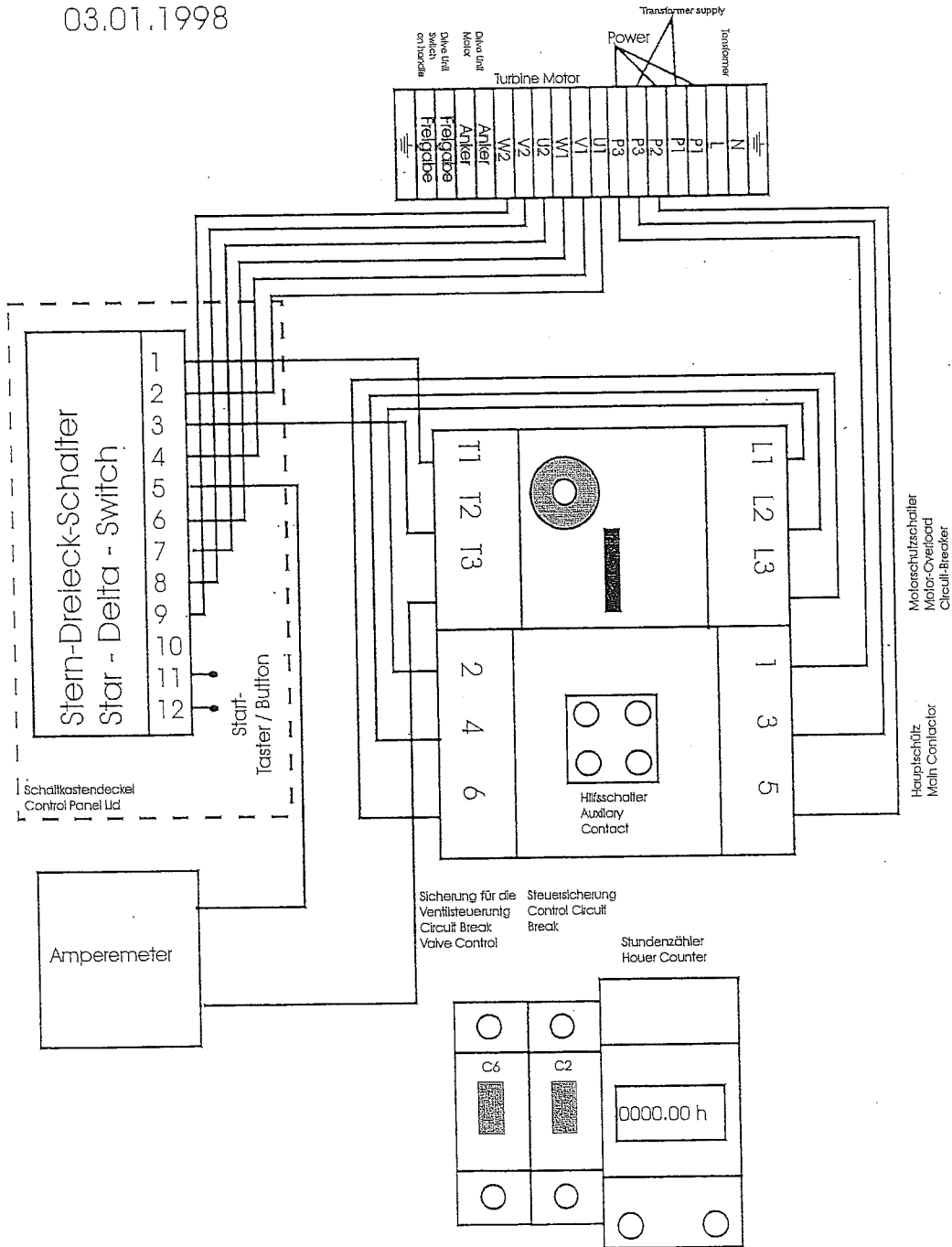

MODUL 350 Rahmen / Frame
 (c) Contec GmbH 2003

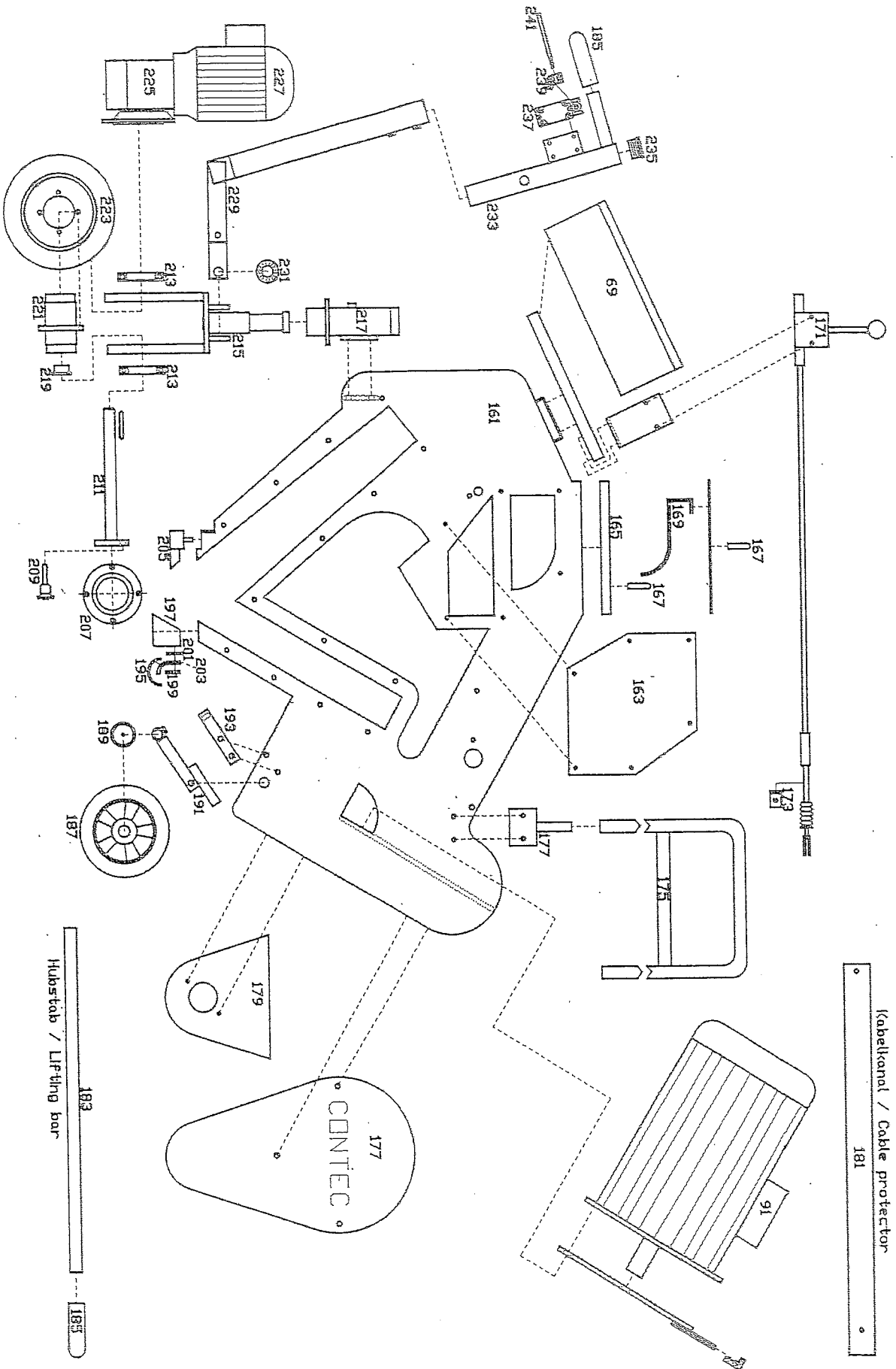

1
2
3
4
5
6
7
8
9
10
11
12
13
14
15
16
17
18
19
20
21
22
23
24
25
26
27
28
29
30
31
32
33
34
35
36
37
38
39
40
41
42
43
44
45
46
47
48
49
50
51
52
53
54
55
56
57
58
59
60
61
62
63
64
65
66
67
68
69
70
71
72
73
74
75
76
77
78
79
80
81
82
83
84
85
86
87
88
89
90
91
92
93
94
95
96
97
98
99
100

MODUL 350 Turbine, Strahlmittelzufluss, Seitenplatte /
 Turbine, Shot valve, Side plates
 © Contec GmbH 2003

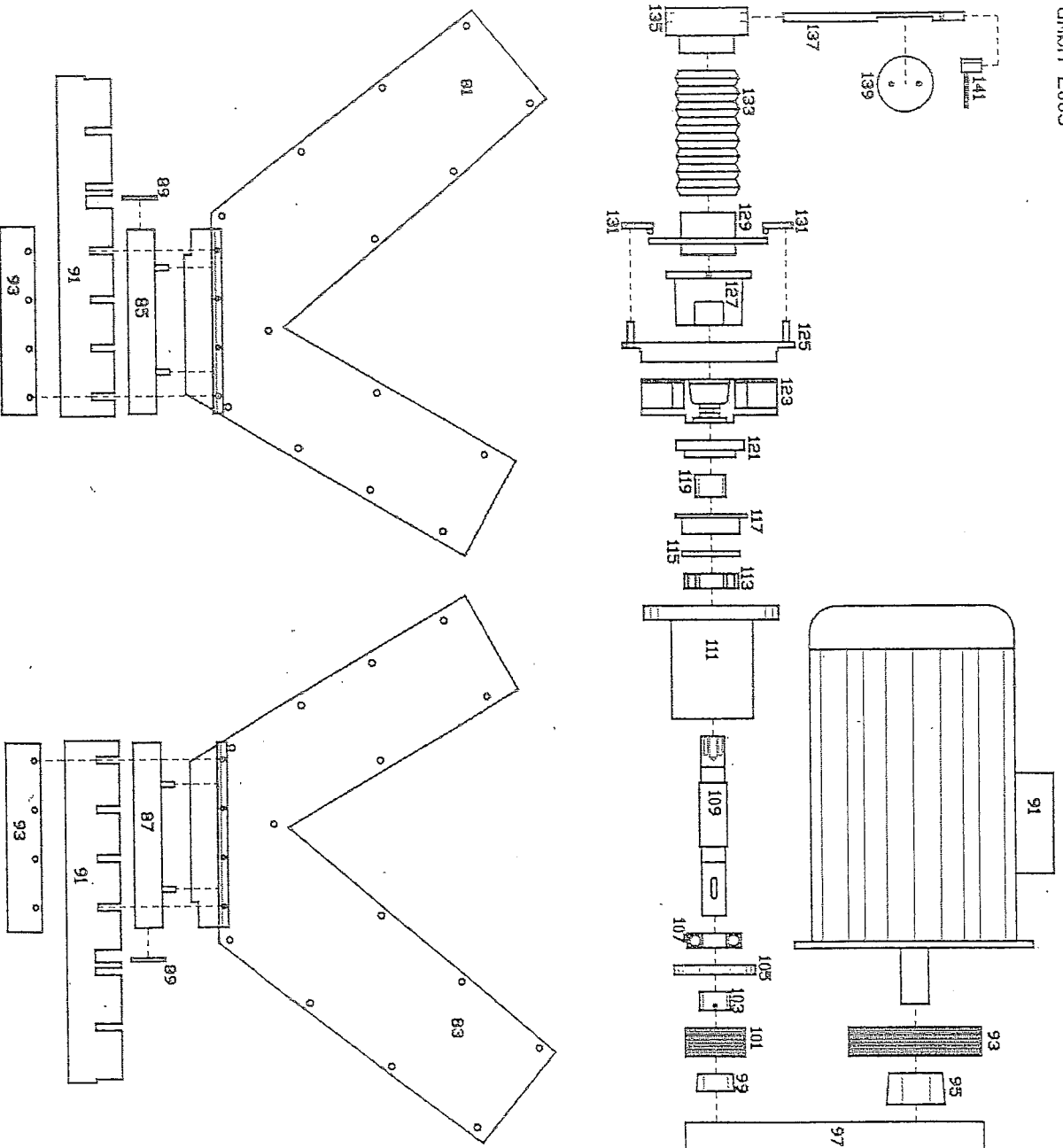

1
2
3
4
5
6
7
8
9
10
11
12
13
14
15
16
17
18
19
20
21
22
23
24
25
26
27
28
29
30
31
32
33
34
35
36
37
38
39
40
41
42
43
44
45
46
47
48
49
50
51
52
53
54
55
56
57
58
59
60
61
62
63
64
65
66
67
68
69
70
71
72
73
74
75
76
77
78
79
80
81
82
83
84
85
86
87
88
89
90
91
92
93
94
95
96
97
98
99
100

MODUL 350 Innenverkleidungen / Liners
(c) Contec GmbH 2003

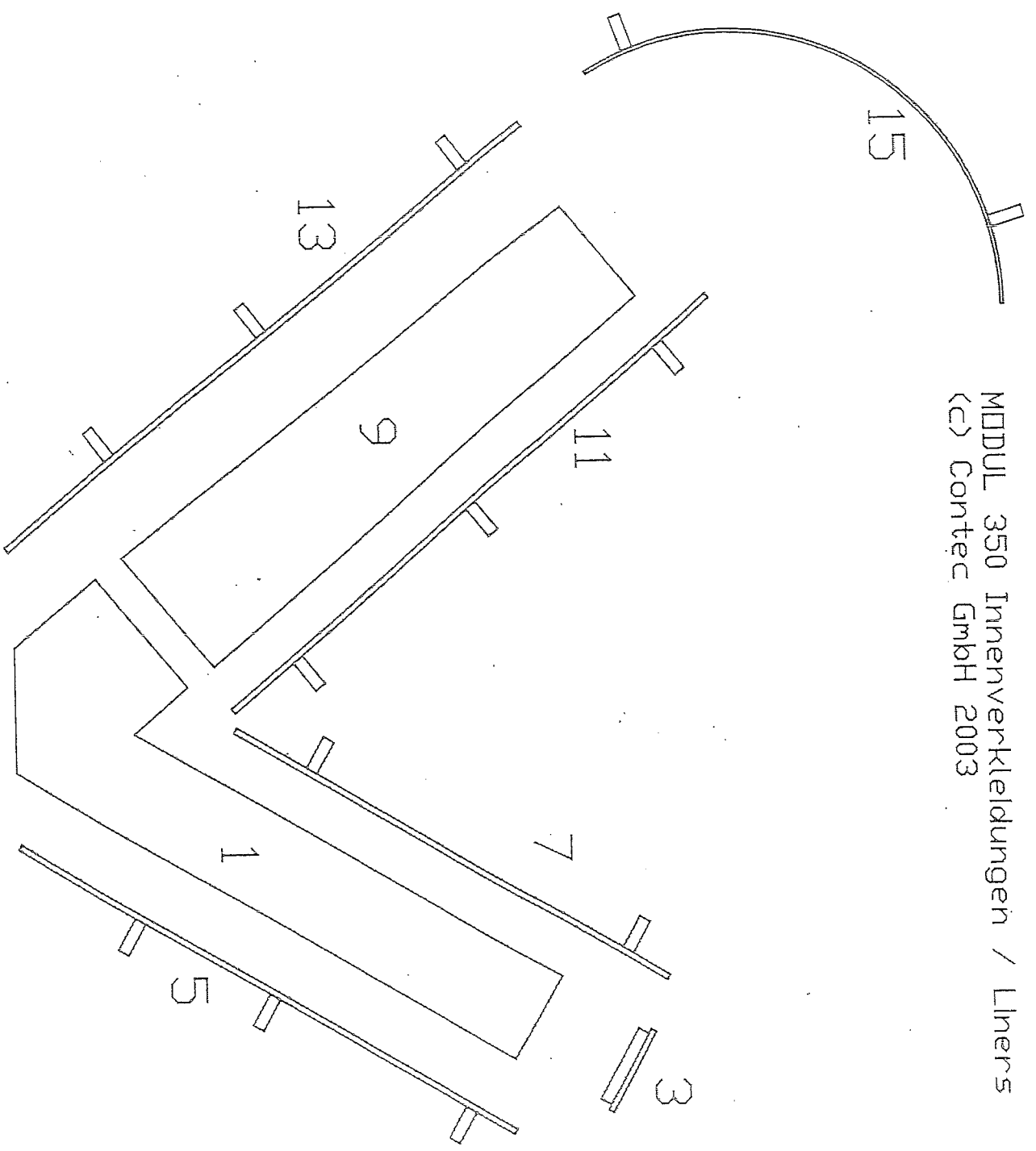

1
2
3
4
5
6
7
8
9
10
11
12
13
14
15
16
17
18
19
20
21
22
23
24
25
26
27
28
29
30
31
32
33
34
35
36
37
38
39
40
41
42
43
44
45
46
47
48
49
50
51
52
53
54
55
56
57
58
59
60
61
62
63
64
65
66
67
68
69
70
71
72
73
74
75
76
77
78
79
80
81
82
83
84
85
86
87
88
89
90
91
92
93
94
95
96
97
98
99
100

MODUL 350 Schaltschrank / Control Panel
 (c) Contec GmbH 2003

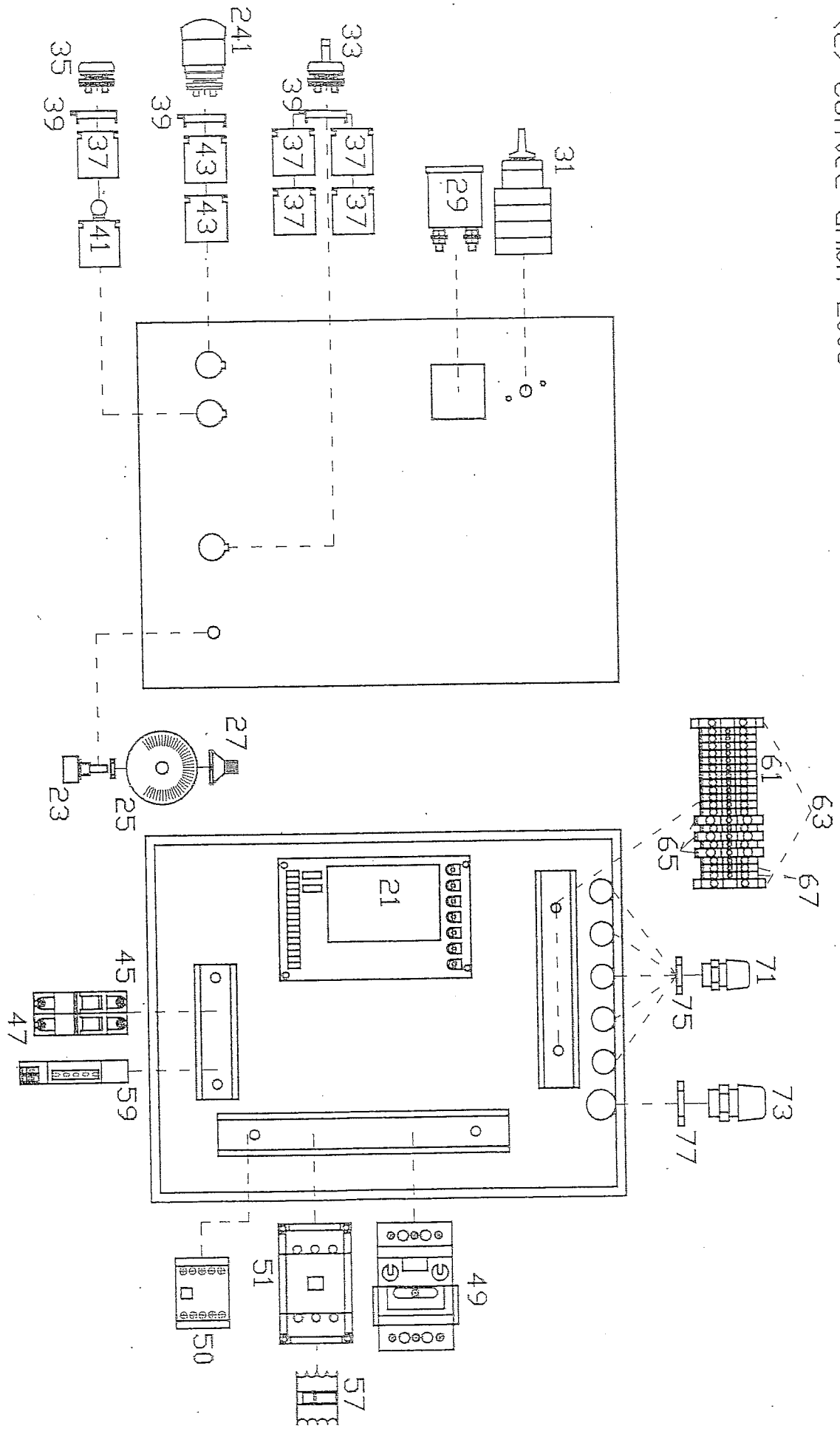

1
2
3
4
5
6
7
8
9
10
11
12
13
14
15
16
17
18
19
20
21
22
23
24
25
26
27
28
29
30
31
32
33
34
35
36
37
38
39
40
41
42
43
44
45
46
47
48
49
50
51
52
53
54
55
56
57
58
59
60
61
62
63
64
65
66
67
68
69
70
71
72
73
74
75
76
77
78
79
80
81
82
83
84
85
86
87
88
89
90
91
92
93
94
95
96
97
98
99
100

Modul 350 Stückliste / Parts List

AGR	Artikel-Nr.-Part-No.	Description 1	Description 2	D-Nr.
031	21-12-00-08	Side Lining Blast Chamber M350		1
031	21-12-00-05	Top Lining Blast Chamber M350		3
031	21-12-00-03	Back Lining Blast Chamber to the Bearing	Housing M350	5
031	21-12-00-04	Front Lining Blast Chamber Blast Wheel	Cover Side M350	7
031	21-12-00-07	Side Lining Reclaim Chamber M350		9
031	21-12-00-02	Back Lining Reclaim Chamber inside M350		11
031	21-12-00-01	Front Lining Reclaim Chamber M350		13
031	21-12-00-10	Liner Reclaim Chamber Round M350		15
033	50-20-30-63-A	Fuse 6,3 A for control cercuit M200/M350		20
033	50-20-30-15	Drive Circuit Modul 200/350		21
033	50-20-30-10-A	Fuse 10 A for Drive control M200/M350		22
033	50-20-30-16	Potentiometer Modul 200/350 with Knob		23
033	50-20-20-11	Speed Scale Modul 200/350		25
033	50-20-20-10	Potentiometer Speed Button only		27
033	50-20-30-12	Ampmeter 42 A Modul 350	Modul 200/350	29
033	51-20-30-00	Cover for Ampmeter 48 mm		30
033	51-20-20-04	Star-Delta Switch Modul 200/350		31
033	50-20-23-03	Direction Switch Modul 200/350 new		33
033	50-20-23-02-N	Start Button with Light Modul 200/350	Version Mai 2003	35
033	50-20-33-07	Contact Element K10 Modul 200/350 new	new Version 2003	37
033	50-20-23-09	Mounting Adapter for Switches Modul 200/	Version Mai 2003	39
033	50-20-33-061	LED Element for bulb Modul 200/350 new	350 new Version Mai 2003	41
033	50-20-33-08	Contact Element M22-K01 Modul 200/350	Version 2003	43
033	50-20-30-02	Circuit Breaker Drive Unit C6	new Version Mai 2003	45
033	50-20-30-03	Circuit Breaker Control C2 Modul 200/350	Modul 200/350	47
033	51-20-21-01	Motor Protective 15 KW, 400 Volt	Modul 350	49
033	50-20-30-17	Contact for Fast Speed Modul 350		50
033	51-20-31-04	Main Contactor Modul 350		51
033	50-20-20-15	Reverse plug 32 A, 400 Volt Modul 350		52
033	50-20-30-05	Auxiliary Contact Module Main Contactor		57
033	50-20-30-13	Hour Counter Modul 200/350	Modul 200/350	59
033	51-10-10-30	Control Panel Box only Modul 350		60
033	50-10-11-00	Complete Control Panel MODULE 350		69
032	35-10-01-03	Bracket Control Panel right M350		70
032	35-10-01-01	Bracket Control Panel left M350		70
032	35-10-01-02	Bracket For Control Lever at the Control	Box Modul 350	72

Modul 350 Stückliste / Parts List

032	35-10-11-00	Side Cover Right M350		81
032	35-10-10-00	Side Cover left M350		83
031	30-10-14-00	Right Magnetic Frame M200/M350		85
031	30-10-13-00	Left Magnetic Frame M200/M350		87
032	35-10-24-02	Bracket For Magnetic Frame Front M350		89
032	35-10-06-00	Belt Holding Fixture M350		90
031	75-23-80-06	Rubber Sealing For Magnetic Frame M350		91
033	50-20-10-15	Turbine Motor 15 KW, 400 V, 50 HZ M 350		91
032	30-10-24-01	Bracket for magnetic frame rubber left		93
032	90-24-01-90	Large Pulley M350	and right M350/M200	93
032	30-10-23-00	Bracket f. Belt Holding Fixture for		93
032	90-24-25-17	Taberlock For Large Pulley M350	30-10-06-00 M200	94
032	70-24-32-16	Poly-V Belt M350		95
035	70-24-11-68-US	Poly-V Belt M350 US Version		97
032	90-24-16-10	Taberlock For Small Pulley M350		97
032	90-24-00-82	Small Pulley M350		99
035	90-24-10-25-US	Small Pulley M350 US Version		101
032	35-17-19-04	Turbine Axis rear Ring to the Pulley		101
032	35-17-20-02	Cover for Bearing Housing Belt Side M350	M350	103
032	61-20-63-07	Bearing Housing, rear Bearing to the		105
032	35-17-19-00	Turbine Axis M350	Pulley M350	107
032	35-17-20-01	Bearing Housing Turbine M350		109
032	61-20-03-07	Bearing for Turbine Axis Blast Wheel	Side M350	111
032	61-20-35-80	Sealing Bearing Housing M350		113
032	35-17-20-03	Cover for Bearing Housing Blast Wheel		115
032	35-17-19-03	Turbine Axis front Ring to the Blast	Side M350	117
031	35-17-18-07	Blast Wheel Socket M350	Chamber M350	119
031	95-10-18-01	Casted Blast Wheel Round Centre M350		121
032	35-10-17-00	Blast Wheel Cover M350	Incl. screw	123
031	95-15-18-07	Shot Cage M350		125
032	35-10-17-04	Shot Enter Pipe M350		127
032	30-10-17-04	Shot Enter Pipe Fixture M200		129
032	70-26-70-80	Shot Hose flexible M350		131
032	35-14-16-01	Shot Valve Alu-Pipe With Magnets M350		133
032	35-10-16-02	Shot Valve Axis M350		135
032	35-10-16-03	Shot Valve Disk M350		137
032	30-10-16-04	Shot Valve Lever		139
				141

Modul 350 Stückliste / Parts List

033	50-29-08-00	Transformer M350		158
033	50-10-15-02	Transformer Box Modul 350		160
030	15-10-00-00	Machine Frame M350		161
032	70-27-00-70	Side Cover right Filler Cap Shot	compartment Modul 350	162
032	35-10-27-01	Side Cover Shot Compartment right M350		163
032	35-10-27-00	Side Cover Shot Compartment left M350		164
032	35-10-04-00	Shot Compartment Sleeve without Handle	M350	165
032	70-27-10-70	Plug for Covering left Modul 350		166
032	90-21-50-16	Handle Aluminium 160 mm Modul 350		167
032	35-10-05-01	Shot Compartment Lit without Handle and	without Shot Stop M350	168
032	35-10-05-02	Shot Stop M350		169
032	90-20-00-10	Control lever M350/M200/Elephant		171
032	30-10-07-01	Bracket for Shot Valve Lever at the	Frame of the Machine Modul 200/350	173
032	35-10-28-02	Hose Support Arch M350		175
032	35-10-28-01	Hose Support Bracket M350		177
032	35-10-25-02	Belt Cover M350		177
032	35-10-25-03	Belt Cover Rear Plate M350		179
032	35-10-07-00	Cable Pipe M350		181
032	35-10-09-00	Lifting Bar M350		183
032	70-21-26-10	Rubber Grip M350		185
032	80-20-32-00	Rear Wheel M350		187
032	35-10-08-04	Rear Wheel Shaft M350		189
032	35-10-08-00	Rear Axis M350		191
032	35-10-08-05	Highs Adjustment Rear Axis M350		193
031	35-13-15-01	Back Skirt half pipe M350		195
032	35-10-26-00	Retaining Plate For Back Skirt M350		197
031	75-23-00-06	Back Skirt Rubber M350		199
032	35-10-15-02	Bracket Back Skirt M350		199
031	75-23-35-03	Back Skirt Rubber for distance M350		201
031	35-10-12-00	Front Magnetic Frame M350		205
032	35-10-02-05	Drive Axis Cover M350		207
032	90-25-00-01	Clutch Pin M350/M200		209
032	35-17-02-02	Drive Axis M350		211
032	61-20-60-13	Bearing For Drive Unit M350		213
032	35-10-02-03	Drive Unit Frame M350		215
032	35-10-02-04	Lifting Tube M350		217
032	61-25-32-39	Drive Hub Bronze Bush Modul 350		219

Modul 350 Stückliste / Parts List

032	35-17-02-01	Drive Hub where the Drive Wheel is	connected M350	221
032	80-20-32-50	Drive Wheel M350		223
033	50-20-20-51	Drive Unit Motor 500 Watt without Gear-	box Modul 350	227
032	35-10-03-02	Drive Lifting Arm M350		229
032	35-10-02-10	Axis to connect Drive with lift Arm M350		230
032	61-20-62-05	Bearing For Lifting Arm M350		231
032	35-10-03-03	Handle Bar M350		233
033	50-20-30-19	Push Button Acuator Fast Speed Modul 350		234
032	70-27-45-45	Plastic Plug for Top Handle Modul 350		235
033	50-20-30-18	Contact Element for Fast Speed E 10	Modul 350	236
033	50-20-10-01	Drive Unit Switch M200/M350		237
033	30-10-03-04	Drive Unit Lever Alloy Modul 200/M350		239
033	50-20-23-01	Emergency Switch Modul 200/350 new	Version Mai 2003	241
031	35-10-15-00	Back Skirt complete M350		
031	35-10-30-01	Back Skirt half pipe M350/2		
031	35-10-30-00	Back Skirt complete M350/2		
031	21-12-00-11	Seperating Lining Blast Chamber M350/2		
031	21-12-00-12	Seperating Lining Blast Chamber M350/2		
031	Blastrac	Blast Wheel Socket Blastrac 1-10; 1-15DS		
031	99-20-20-20	Casted Blast Wheel Round Centre 4 Blades	complete with Cage for Blastrac	
031	75-23-00-07	Back Skirt Rubber M350/2		
032	35-10-16-05	Sealing for Shot Valve M 350		
032	35-10-16-00	Complete Shot Valve With Gasket M350		
032	35-10-125-150	Connecting Pipe 2x125mm/1x150mm	Modul 350/2	
032	35-10-25-04	Treaded Rod Belt Cover M350		
032	35-17-20-00	Bearing Housing complete M350 with Axis,	Bearings, Cover	
032	50-20-20-53	Drivemotor Cover Ventilator for 500 Watt	Motor Modul 350	
032	50-20-20-54	Ventilator for 500 Watt Drive Motor	Modul 350	
032	50-20-20-52	Drive Motor Bearing Flange B-side 500	Watt Modul 350	
032	61-20-M350	Bearing Set complete Modul 350	Front, Back and Sealing	
032	71-23-17-06	Gasket Blast Wheel Cover 3 mm M350		
032	71-23-17-05	Gasket Blast Wheel Cover 1 mm M350		
033	50-20-20-50	Drive Unit Motor with Gearbox 500 Watt		
033	50-20-20-36	Drive Unit Motor M350	Modul 350	
033	50-20-20-63	Plug 63 A, 400 Volt, 5 pin Modul 350/2		
033	50-20-10-02	Drive Unit Switch only Top Part with	Axis M200/M350	
033	50-10-11-01	Complete Control Panel MODUL 350 +	MODUL 350 EU	

Modul 350 Stückliste / Parts List

033	50-20-20-125-1	Drive Unit Gear Box 125:1 Standard M350	
033	50-20-20-35	Drive Unit Motor M350	
033	50-20-20-06	Label Mount (Start) 111 Modul 200/350	
033	50-20-20-05	Label Mount 93 (I O II) Modul 200/350	
033	50-20-20-100-10	Drive Unit Gear Box 100:1 M350	Spindel for Motor
033	50-20-20-10-20	Carbon Brush for Drive Unit Motor M350	350 Watt
033	50-20-20-100-1	Drive Unit Gear Box ratio 100:1 fast	Speed Modul 350
031	75-23-35-04	Back Skirt Rubber for distance M350/2	
031	75-23-80-16	Rubber Sealing for Magnetic Frame M350/2	
032	35-10-08-10	Rear Axis M350/2	
032	35-10-24-10	Bracket For Magnetic Frame Front M350/2	
033	50-10-11-00-2	Complete Control Panel MODULE 350/2	

